

*“Standard - Horizontal  
System”*

## **SINGLE LINE FLOOR CONVEYOR**

### **TYPE SDH**

The SDH floor conveyor system is a fixed pitch floor conveyor system designed for either continuous or stop/go operation.

Developed by Caldan for applications where smaller unit loads such as mobile telephones need to be processed effectively and in high volume.

As with all our floor conveyor systems the SDH is developed for high accuracy of presentation and stability.

Typically fitted with our high speed rotation system for automated coating processes.

Maximum load per carrier – 30 kg.

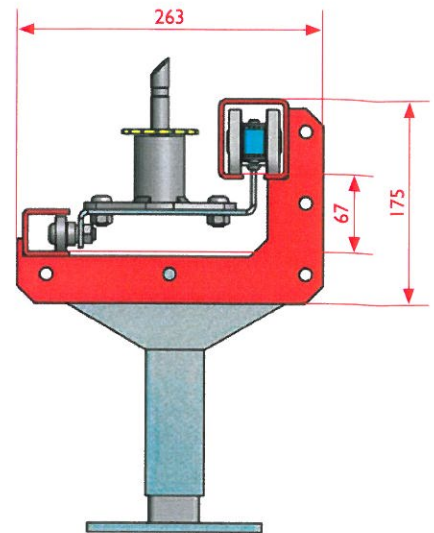
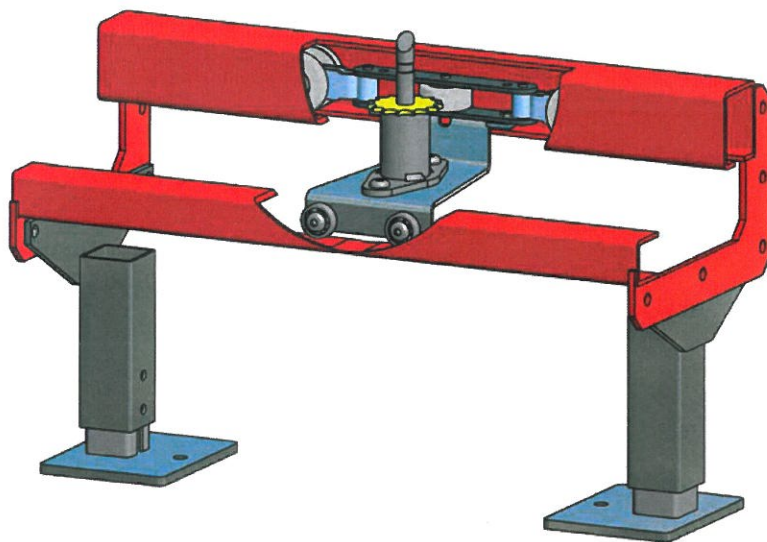

### Specifications:

The Floor conveyor type SDH consists of a Caldan standard straight profile.

In the profile a cardan chain is driven by a drive unit with fixed or variable speed.

The waggon body consists of 4 mm laser cut and folded plates assembled with a minimum of welding operations. The load capacity of the waggon is max. 30 kg.

Turning devices non-fixable or fixable in 90° or 180° positions are mounted on the top of the waggons on customer request.

### Technical data:

Chain pitch: 270 mm  
 Chain bearings: Open or sealed and greased version  
 Max. chain pull: 400 kg  
 Max. temperature (surroundings): 250°  
 Max. load per trolley: 30 kg  
 Standard length, straight profile: 3.000 mm - equipped with flanges

Horizontal curves:  
 Degree: 90° / 45° / 30° / 15°  
 Radius: 500 / 700 / 1.000 mm

Vertical curves:  
 Degree (depending on work-load): 15° / 30°  
 Radius: 1.000 mm

All horizontal and vertical curves can be manufactured in special radii on request.

Drive unit: Straight version, single sided caterpillar drive. Gear motor with fixed or variable speed

Tension unit: Manual or pneumatic/ weight-loaded

Pneumatic lubrication: Semi- or fully automatic version. Point- or fog lubrication of the cardan chain

Special equipment: Motorized or pneumatic turning stations

Accumulation possibilities: None