



POWER & FREE FLOOR CONVEYOR

TYPE P&F 120

Based on exactly the same profile and drive system technology as the other 100 system conveyors the P&F 120 system is a self accumulating Power & Free system.

Developed for applications where the need for Power & Free technology is required in sections such as storage areas, ovens etc. where space is at a premium but where general process areas only require fixed pitch operation.

- Possibility to accumulate in line
- No need for expensive control systems for accumulation sections due to self accumulating design
- Switch wagons (load carriers) from lane to lane
- Incorporate vertical lift/lower stations
- Operate at different process speeds on the same line

Maximum load per carrier – 200 kg.

“The self accumulating system”

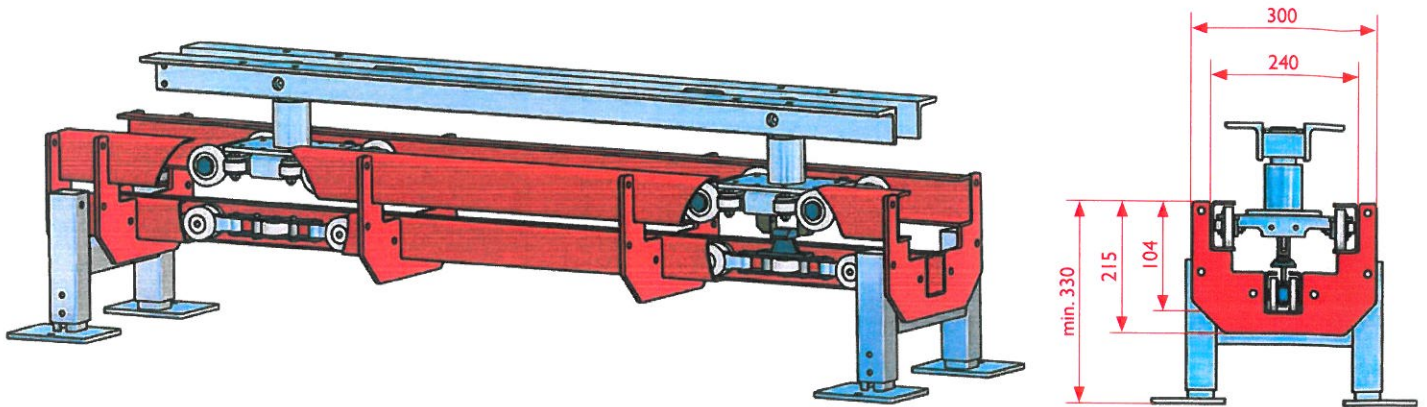

Specifications:

The Power & Free floor conveyor, Type P&F 120, consists of three Caldan profiles. In the lower "Power" profile the cardan chain is driven by one or more drive units. In the upper "Free" profiles the purpose designed trolley and wagon sets are driven by power chain carriers, which engages the inwards pivotal links underneath the trolley.

The trolley body is made of 5 mm. laser cut and folded plates and is equipped with 4 sealed load carrying wheels and 4 sealed horizontal wheels for side guiding.

The power chain carrier pitch is designed according to customer specification. Each trolley and wagon set can be separated from the power chain and accumulated in line.

The accumulation is carried out by lowering the power chain at the beginning of the accumulation zone.

Conveyance with loads in rise and fall sections is possible due to a uniquely designed link between the chain carriers and the trolley.

Technical data:

Chain carrier pitch:	180 / 270 mm
Max. chain pull:	400 kg
Max. temperature (surrounding):	250° C
Max. load per 4-wheeled trolley:	200 kg
Max. load per wagon (load bar with two trolleys):	400 kg
Standard length, straight profile:	3.000 mm

Trolley bearings: Closed and greased for low maintenance

Horizontal curves:
Degree: 90° / 45° / 30° / 15°
Radius: 500 / 700 / 1.000 mm

Vertical curves:
Degree (depending on work-load): 30° / 15°
Radius: 1.000 mm

Special dimensions on request.

Drive unit: Straight double sided version with caterpillar chain drives

Tension unit: Manual and pneumatic version

Lubrication: Pneumatic point lubrication – automatic

Accumulation features: In line

Special features: Turning stations and drop sections