



## POWER & FREE CONVEYOR

### TYPE P&F380

The flexible P&F system with a load capacity up to 800 kg.

Simple and reliable accumulation of wagons in in line, 45° and in 90° buffer zones.

Smooth trolley transfer from one conveyor circuit to another minimizes the use of transfer units, thus lowering systems costs.

Unique trolley- and accumulation stop design ensures an instant and a highly reliable separation of wagons in the accumulating zones.

The use of modular components offers total flexibility and liberty in configuring the conveyor circuit layout.

Consequent use of tested quality components giving confidence in operation even in very harsh working environments.

Noiseless accumulation by means of non friction disengagement of the trolleys from the conveyor chain drive.

*“The light, all-round P&F system  
for your materials handling”*

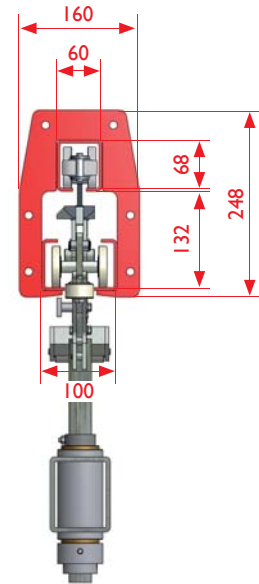
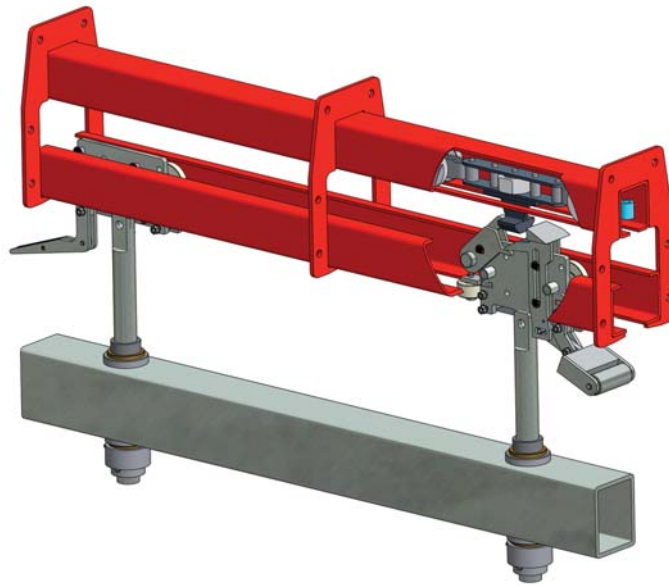

**Specifications:**

The Power & Free conveyor type P&F 380 consists of two Caldan straight profiles. In the upper "Power" profile a cardan chain is driven by one or more drive units.

In the underlying "Free" profile the wagons are driven by power chain carriers, via pivotal pawls attached to the front and back of the trolley.

Both the chain carrier pitch and the accumulation distance is designed according to customer request.

The wagons can, according to handling requirement, be separated and accumulated either in line, or at 45° or 90° within accumulation zones.

When routed into a closed accumulation stop, or when reaching the "tail" of the previous trolley, the trolley's accumulation lever is lifted and the pawl units are lowered. Hereby the trolley is disengaged from the chain carriers.

Conveyance with loads in up to 30° rise and fall sections - depending on the load - is possible due to a uniquely constructed link between the chain carriers and the trolley pawls.

**Technical data:**

Chain carrier pitch: 180 / 270 mm  
 Max. chain pull: 400 kg  
 Max. temperature (surrounding): 250° C  
 Max. load per trolley (4-wheeled): 200 kg  
 Max. load per wagon (load bar with 2 / 4 or 8 trolleys): 400 / 800 kg  
 Standard length, straight profile: 3.000 mm  
 Trolley wheels / chain bearings: Open or sealed and greased version

Horizontal curves:  
 Degree: 90° / 45° / 30° / 15°  
 Radius: 700 / 1.000 mm  
 Vertical curves:  
 Degree (depending on work-load): 15° / 30°  
 Radius: 1.000 / 1.500 / 2.500 mm

Drive unit: Straight version with double sided caterpillar drive or 90° version with driving wheel. Gear motor with fixed or variable speed

Tension unit: Manual or pneumatic / weight-loaded  
 Switching gate: Manual, pneumatic or electrical version  
 Vertical drop- and lift section: Available in guided / floor mounted version or un-guided and suspended from the ceiling

Accumulating stop: Pneumatic or electrical version

Pneumatic lubrication: Semi- or fully automatic version. Point- or fog lubrication of the cardan chain and / or the trolleys

Special designs: E.g. turning stations  
 Accumulation possibilities: Automatic. In-line, 90° and 45°